

# Sportscar SE-A4

## Tools and resources

To assemble this kit you should prepare the following tools not included in the kit: Allen-key SW1,5, tweezers, needle-nosed pliers, Allen-key SW2,5, Torx screwdriver 6,8,10,20. (May be ordered in the shop)

Included in the kit you will find: 1 small syringe of ceramic paste (dry), 1 small syringe of Aeroshell Fluid 12 oil, **Puncher 1,5mm (54) to remove mounted aligning pins and holding plates ( 55, white) for aligning pin assembly.**

## Assembly

### 1 – ASSEMBLY::: MOTOR BLOCK:::

Push the axis (5) into the flywheel (3) and attach it with the headless screw (15) push a bearing (4) on the axle. Screw the headless screw (15) in the propulsion wheel A (6). Set the O-ring A (10) in the groove of the propulsion wheel A (6), hold these together and guide into the deep hole of the motor block (1) placed on its back so that the belt line coincides with the slot towards outside. Now drive the mounted flywheel (3) with the axle and the bearing into the bearing bore of the motor block (1), through the propulsion wheel (6) and out the other side. Push another bearing (4) into the bearing bore of the motor block (1) at the end of the axle (5). Now add the other flywheel (2). This can be attached with the headless screw (15). A bore hole is set on the circumference of the wheels (2+3) and should lie exactly on the same line. Guide the bearing (4) on the transmission axle (8). Now drive the axle through the bearing bore of the outlying axle stub of the motor block (1), through the propulsion wheel B (7) and through the second axle stub (1). From this side you may drive the other bearing (4) onto the transmission axle (8) up to the bearing bore (including the threaded O-Ring A (10)). Circlips are to be clipped onto both sides of the axle (8). The propulsion wheel (7) can now be attached in a centered position using the headless screw (15) with the 1,5mm Allen-key. The flywheels should now be able to turn freely. The first assembly is now complete!

### 2-ASSEMBLY:::SEAT BLOCK:::

The displacement piston cover (20) should be placed on the table flat side down and the displacement piston (19) pushed in vertically until the table is reached. Add some lacquer or thread locker on the inside threading of the displacement piston using a toothpick and screw on the displacer axle (18) up to the catch.

Carefully remove overflowing lacquer using a cloth (approx. 2h drying time). Push the brass barrel (16) into the seat block (12) and attach using the countersunk screw (17).

Push the mounted displacement piston (18/19/20) into the barrel (16) (from the inside). If the seat block is held vertically, the displacement piston should fall in by itself – it should not jam. Cleanliness is important!

Put the heating cylinder (23) onto the seat block (12) and attach using 4 Allen screws (24). Pull the working cylinder (56) out of the barrel and set it aside.

Now push the barrel – working cylinder (13) and push in a line with the horizontal holes in both M3 threaded holes on the outside of the seat block slowly and carefully up to the catch so as to be able to see through the second threaded bore and through the barrel hole (2,5mm) from the outside. Rotate the headless screw M3x4(14) into the hole until it is flush with the outside. For the hole on the edge of the seat block, take the headless screw (15) M3x3 and turn it carefully up to the catch so as to secure the barrel.

Push both ball bearings (4) into the seat block from one side. Push a circlip respectively onto the axles 25+26 (in each case the inside groove) and clip in. Now drive into the bearing up to the catch with the inside circlip in accordance with the figure. Push another bearing respectively over the axis and press into the bearing seat. Now also clip a circlip into the groove so as to block the axle.

Using the plastic insert assistance (55), set the aligning pin (21) on the sunken side of the piston (56) and carefully attach VA piston rod (22) using needle nosed pliers. Rub out a minimum amount of white ceramic paste (open with side cutters) between thumb and index finger until almost no paste is visible. Now apply a very thin film of ceramic paste on the working cylinder (56) with the index finger. Guide the piston (56) into the barrel (13) and move back and forth. The piston (56) should not scratch or jam! Perform the same aligning pin assembly on parts 18 and 22.

Using the provided syringe, apply a minimal droplet of oil on the displacement axle (18).

The second assembly is now finished!

### 3-ASSEMBLY :::Final assembly frame:::

Attach the license plate (38) on the front of the frame (self-adhesive, remove foil). Attach the central part (32) with the front axle (31) with the help of aligning pin (33) (Again, use the white plate so as to attach the pin). Now push in mounted central part from below into the frame (Pay attention to the correct side “up, down” see rear left for both holes on the left side in the direction of driving) and screw tight (34+45).

Screw the motor block assembly (1) from the top into the middle aperture of the frame (36) and loosely screw from the bottom with two screws (40). Subsequently attach the footboard (39) loosely with both screws (40). Now push the motor block (1) and the footboard to the back and carefully tighten the screws. Now once again assemble both piston rods (43) to the top of the black part (44) along with sleeve (42) with screw (41). Now drive the steering column (44) carefully into the footboard from the underside (through the round hole). From the top you may now clip a circlip to fasten the assembly. Add a small droplet of lacquer or household glue in the top of the threaded hole (44) and attach the steering wheel (48) with the screw (49) and tighten. Push the seat block assembly from the back of the frame up to the catch of the footboard. Screw in from behind left of both screws (40) and fasten. Now attach both connection rods (22) to the flywheels with white sleeve (42) and screw M2,5x5TX6(42).

Now, when you rotate the flywheel the connection rods should not strike against obstacles and should turn freely.

Place the radiator grill (45) in front of the motor block and attach it using two screws (40).

The logo can now be glued to the front (self-adhesive). The sealing cap (47) should be glued with household glue or lacquer. Mount the propulsion wheels C(11) on the axles 8+25 with screws (15). Mount now the propulsion wheel A (7) with O-belt(10)

on the axle (25), maintaining a certain distance (0,5mm) to the seat block! Set down the belt over the small blade wheel (29) with 2 ball bearings (30). Be careful with both Circlips (9).

You can place the car vertically, balanced on the heating cylinder. Secure it from the side.

Now push the steering holding piece (37) from both sides of the front axle (31) towards the center and clip a circlip (39) on the front axle (31) and then respectively on one flywheel (29) with two bearings (30). Now assemble the piston (43) with the sleeves (42) and screws (41) to the respective steering holding piece (37). Stay to the left of the marking facing with the driving direction towards the left. Also stay to the left of the marking on the other side (shifted).

In this manner you avoid future jamming of the steering.. Test the free running of the pistons with the mounted sleeves. It may be necessary to slightly bend the piston close to the black part (44).

On the part (57), bend the straight piece at the top with the 3 slits in a slight wave so that it does not easily fit into the groove but sits tighter. Secure the burner holder with a screw (40) from the bottom. The edges of the burner holder should be bent so that the burner does not lie loose but sits in the holder by itself. To finish, loosen the seat block, foot plate, motor block and radiator grill (4) and push and hold together all parts named. Now tightly screw in all screws (40) (so as to avoid impacts of the displacer axle against the seat block).

The driver must now enter the vehicle from the right in the direction of travel. Guide his knee in from the side under the steering wheel and rotate him towards the seat. He can now be seated and start the car.

#### **Put the vehicle into operation**

***WARNING: The car should only be operated under constant supervision by persons over 18 years of age. Easily flammable objects should not be kept in the vicinity of the demonstration area. Do not touch the seat block, heating cylinder or the flame area since this could cause burning.***

***Handle denaturated alcohol carefully. Never leave alcohol bottles open.***

***Inappropriate use of the Sportscar can lead to fires! NEVER in CHILDREN'S HANDS!!!***

***The legal regulations for open fires apply when operating the device!***

#### **Operating instructions**

1 – Set up the car in a draught-free place with flat floor/table surface.

2 – Remove the lid of the aluminum burner can and fill up to the marking with **94% denaturated alcohol(fresh fluid!!!)**.

**WARNING: The denaturated alcohol bottle should always be closed again and tidied away:::Danger of explosion:::**

3 – Light the wick. Wick must be out of burner 5mm and be **good bushy**.

4 – **Wait approx. 45 seconds for good heat.**

5 – **Forcefully crank** the flywheel in the direction of driving until the car drives by itself.

• Never leave the car without supervision.

• **Rotate flywheel (3) 180° (see line on the circumference) and the car will drive backwards.**

#### **Maintenance/ Cleaning**

Oil got on the working piston (56)? (After longer standstill possible):

Please towel the working piston with a lint-free cloth and as well its working piston bush (13).

Never re-apply oil, oil has an adhesive effect and stops the car from moving! The car should be stored in a dust-free environment. The smallest pollution can stop the motor from functioning. The adjustments are in the H7-area. All mobile mechanical parts should be free-moving or the motor will not run! Be careful when disassembling – some parts have thicknesses of less than 0,25 mm.

**In case of technical questions** please contact us at

[www.rarecreations.co.nz](http://www.rarecreations.co.nz)

#### **The propulsion principle of the Stirling motor**

The burner heats the air contained in a closed circuit. Due to thermal expansion, the working cylinder and the flywheel are kept in motion. As the working cylinder moves in direction of the wheels, the displacing cylinder is pushed from the seat block into the heating cylinder. Since the displacement body has no seal, the hot air is moved past its outer wall into the front part of the seating block. Since the temperature there is approx. 300°C lower (volume reduction), the cooled air creates a vacuum that sucks the working cylinder back out and maintains the flywheel's motion. The rotating movement pulls the displacing cylinder back into the cooling rib part, allowing for a quick streaming of the cooled air from this chamber into the heating cylinder. The air heats again, expands and provides work once again.

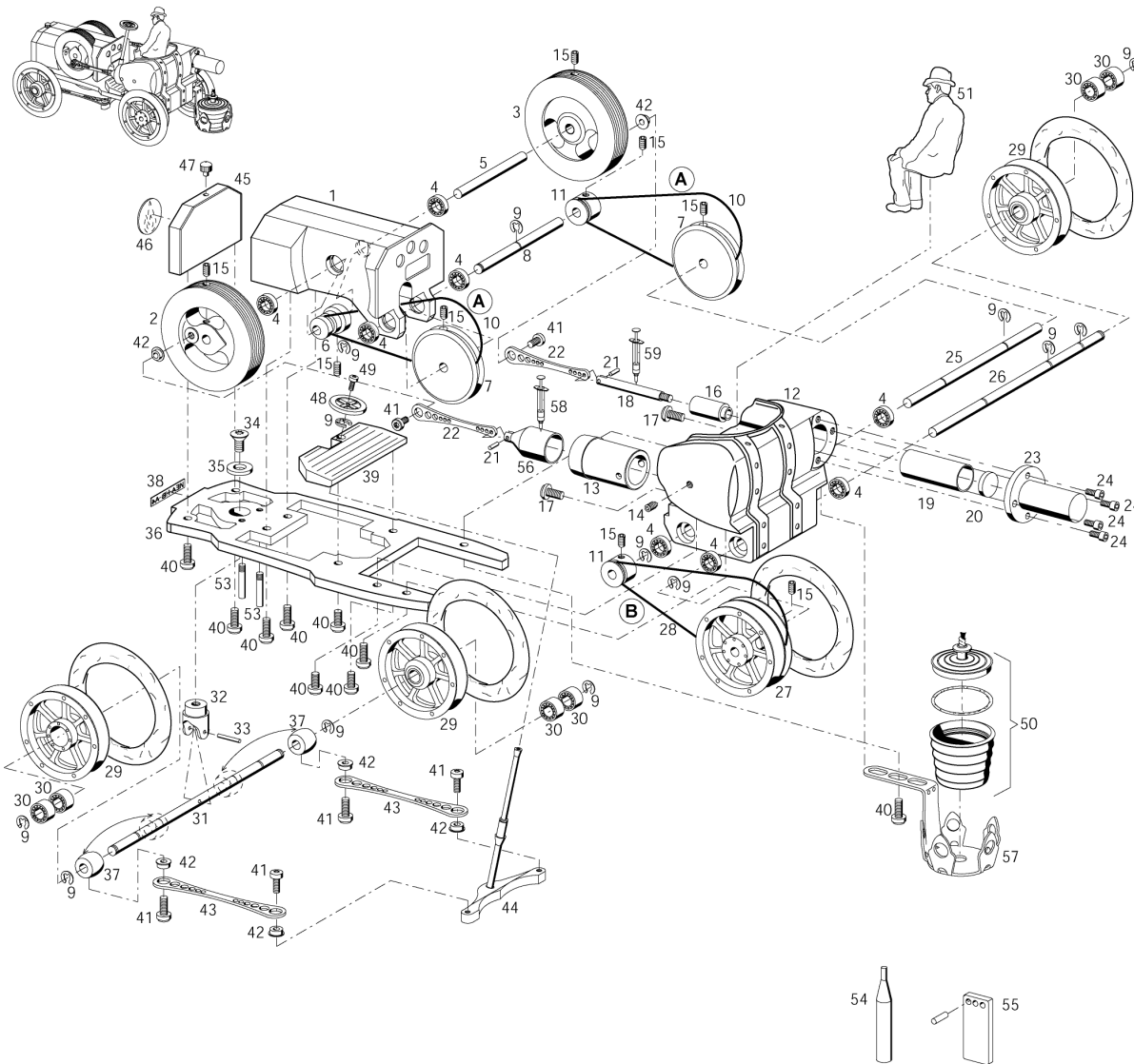

Bild/Nr. Ill. No.	Benennung Part No.	Abm. Bemerk. Diment. Remarks	Stck Pieces	Denomination
1	Motorblock		1	Engine block
2	Schwungrad 180°		1	Flywheel, brass
3	Schwungrad 90°		1	Flywheel, brass
4	Kugellager	∅9x2,5mm	8	Ball bearing
5	Radachse	∅4x34,5mm	1	Axle
6	Antriebsrad A Radachse	∅10x14mm	1	Drive gear
7	Antriebsrad B	∅29x5mm	2	Drive gear
8	Übertragungsachse B1	∅4x44mm	1	Axle
9	Sicherungsring		13	Lock washer
10	O-Ring A	∅33x1,5mm	2	Belt drive
11	Antriebsrad C	∅10x7mm	2	Drive gear
12	Sitzblock Alu		1	Seat block
13	Hlse Arbeitskolben MS	∅18x27,3mm	1	Working piston bush
14	Madenschraube	M4x4mm	1	Grub screw
15	Madenschraube	M3x3mm	8	Grub screw
16	Hlse Verdrngerachse MS	∅8x16,5mm	1	Displace axle bush
17	Flachkopfschraube	M3x6, TX10	2	Pan head screw
18	Verdrngerachse	∅4x33mm	1	Displace axle
19	Verdrngerkolben	∅12x27mm	1	Displace piston
20	Verdrngerkolben Deckel	∅11,6x2,5	1	Displace piston cover
21	Passstift	∅1,5x4mm	2	Pin
22	Pleuel	39,5	2	Connecting rod
23	Heizzyliner	∅25x28mm	1	Heating cylinder
24	Inbusschraube	M3x8mm, SW2,5	4	Sockethead screw
25	Übertragungsachse	∅4x66,5mm	1	Axle
26	Antriebsachse	∅4x89,5mm	1	Drive axle
27	Antriebsrad mit Gummi	62mm	1	Drive wheel
28	O-Ring B	∅41x1,5mm	1	Belt drive
29	Lauf rad mit Gummi		3	Wheel
30	Kugellager	∅9x4mm	6	Ball bearing
31	Vorderradachse	∅4x89,5mm	1	Front wheel axle
32	Zentrallenkstück	∅11,7x13,75mm	1	Central steering
33	Passstift	∅1,5x10mm	1	Pin
34	Senkschraube	M4x6	1	Counter-sunk screw
35	Beilegscheibe	∅11,7x1,5mm	1	Shim
36	Rahmen	125x51x4mm	1	Frame
37	Lenkhaltestck	Messing	2	Steering holder
38	Nummernschild	Klebefolie	1	Numberplate
39	Trittbrett Alu	40,5x17mm	1	Tread
40	Linienkopfschraube	M3x8, TX10	9	Counter-sunk screw
41	Linienkopfschraube	M2,5x5, TX6	6	Counter-sunk screw
42	Bchse Weiss		6	White plastic bush
43	Pleuel Lenkung	62mm	2	Connecting rod steering
44	Lenksule	Messing	1	Steering column
45	Khlergrill	Messing	1	Radiator grille
46	Bhm LOGO		1	Logo
47	Verschlusskappe Grill	VA	1	Locking cap
48	Lenkrad	Messing	1	Steering wheel
49	Linienkopfschraube	M2x4, TX6	1	Counter-sunk screw
50	Spiritus-Brenner		1	Burner case with wick
51	Fahrerfigur		1	Driver figure
53	Anschlagstift	M3x16mm	2	Positioning pin
54	Durchschlag ∅ 1,5	Isen Passtift	1	Drive punch
55	Halteplttchen Passtift Weiss	4x16	1	Holder plate
56	Arbeitskolben	∅13,5mm	1	Working piston
57	Brennerhalterung		1	Burner holder
58	Keramikpaste weiss (fest)		1	White ceramic grease
59	Oil fr Verdrngerachse		1	Oil